

REVISION		ENGINEER	APPROVED	DATE
REV	DESCRIPTION	J. P. LEE	K. D. JANG	2005.11.18
1.0	CONVERSION REVISION			

SPECIFICATIONS

ELECTRICAL

Frequency range : DC~3GHz
 Impedance : Nom. 50Ω
 V.S.W.R : 1.2 Max.

MECHANICAL

- Material/Plating
- Outer conductor : Brass/Nickel
 - Center Contact : Brass/Gold
 - Insulator : PTFE Teflon

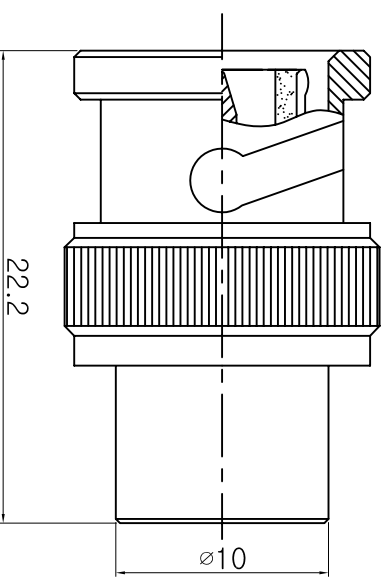

Specified Tolerance		Mat'l		 RFAC Solutions rfacsolutions.com	
.0	±0.1	Finish			
.00	±0.05	Design		Model	BNC
ANG.	±0°30'	Check		Title	MALE TERMINATION
Scale		Approve		Mod.No.	BNC-MA-ST-TERM
Unit		Proj		Part No.	T560-01
N/A		Size			
mm		⌀		J. P. LEE	
		⚠		I. K. HAN	
		A3		K.D. JANG	